



*Saving lives and resources by preventing  
osteoporotic fractures with dairy products*

CERIN-EMF-GDP LUNCH SYMPOSIUM

Dr Mickael Hiligsmann, PhD  
Assistant Professor in Health Economics and Health Technology Assessment

WCO-IOF-ESCEO Florence, 25 March 2017

# Background - implementation of a nutrition program?

Clinical evidence

Societal impact



Economic impact



# Criteria used to assess health products

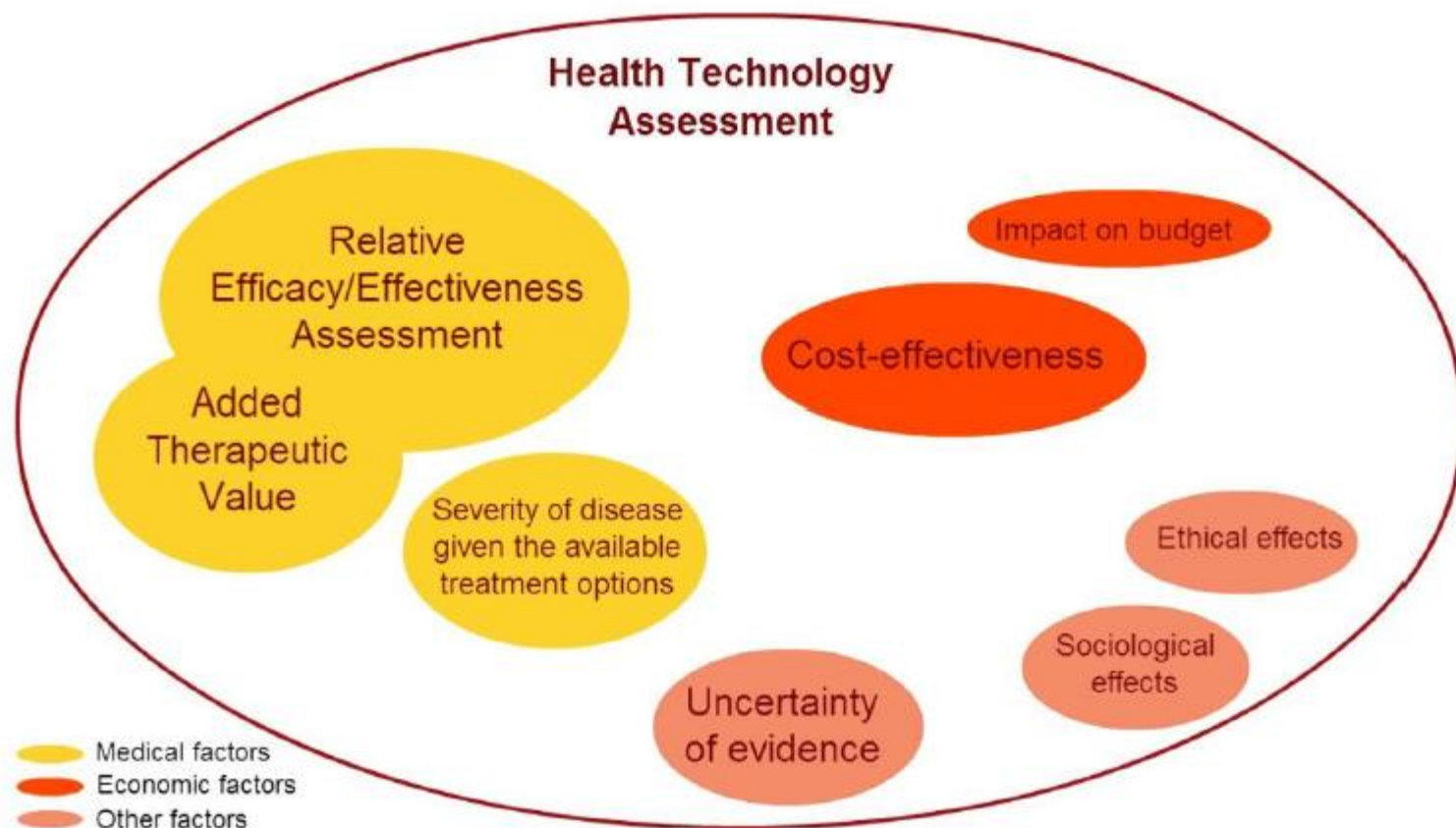

Health Technology Assessment, European Parliament, 2015

## Aim of this presentation



*Dairy products*

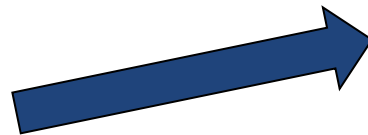

Public health impact

⇒ **Saving lives?**

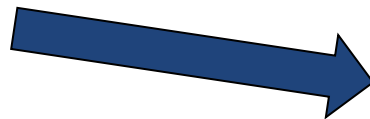

Economic impact

⇒ **Saving resources?**



# Example

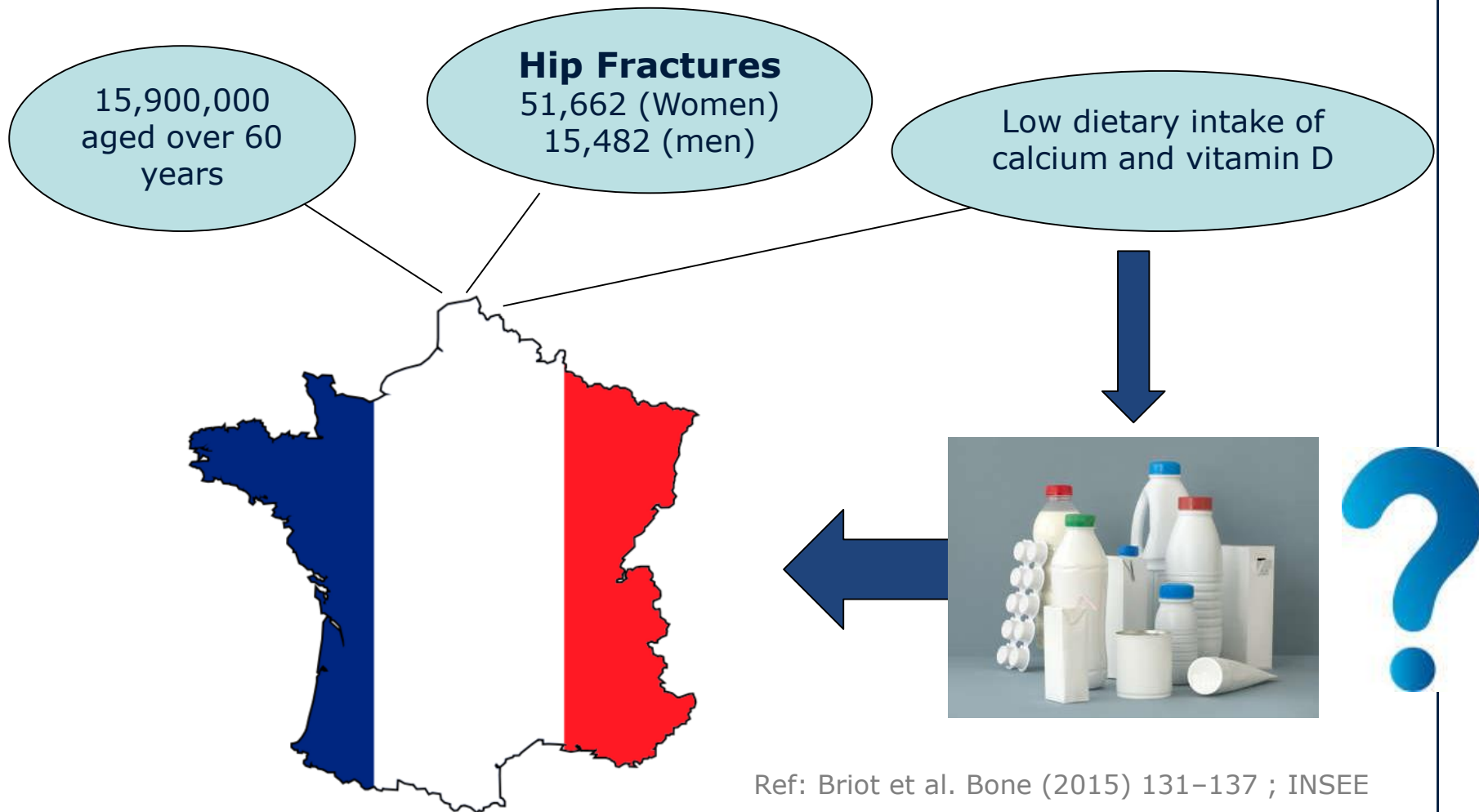

Recommended  
intake of dairy  
products

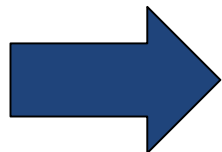

Lifetime impact

- Fractures prevented
- Life years gained
- QALY gained

1 year  
(2015)



Hilgsmann et al. Osteoporos Int. 2017;28(3):833-840

## Methods

### Markov microsimulation model

- Fracture incidence, mortality, fracture cost, fracture disability

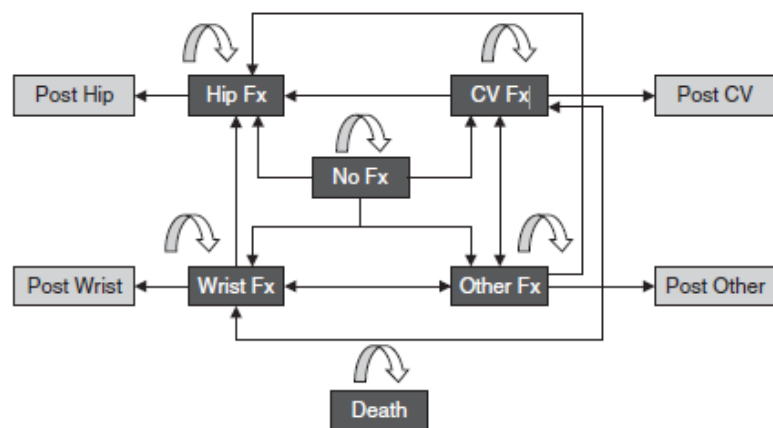

### Dairy products

- Effects on fracture from Cochrane review
- ↓16% (Hip), ↓ 14% (Vertebral) ↓11% (other)

Avenell et al 2014 Cochrane Database Syst Rev 4:CD000227.



## CAPHRI School for Public Health and Primary Care

Health impacts of the recommended intake of dairy products in the general French population over 60 years for 1 year

### Hip fractures

#### First year:

- 8,000 women
- 2,500 men
- ⇒ 126 millions € saved (hospitalization)

#### Subsequent years:

- 7,000 women
- 1,900 men

### Lifetime

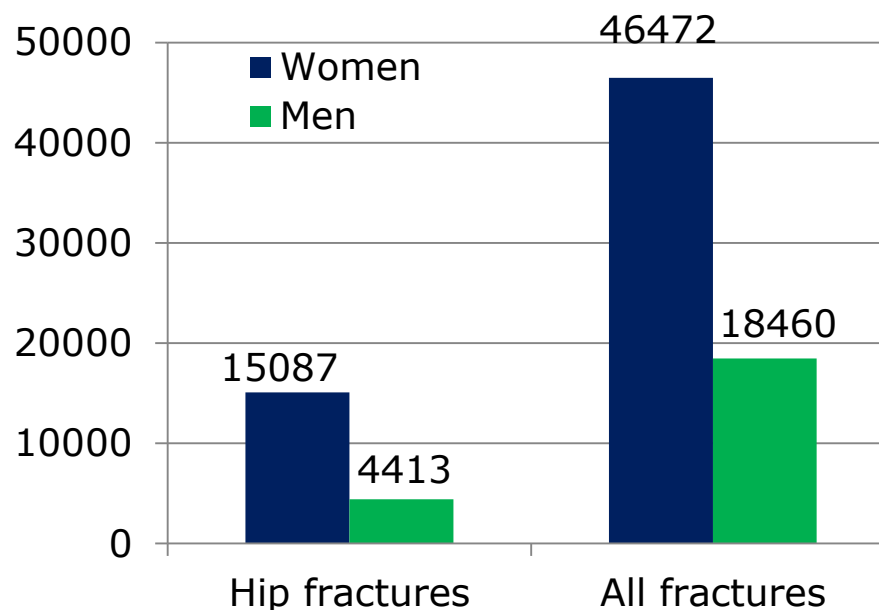

Hilgsmann et al. Osteoporos Int. 2017;28(3):833-840

## CAPHRI School for Public Health and Primary Care

Health impacts of the recommended intake of dairy products in the general French population over 60 years for 1 year

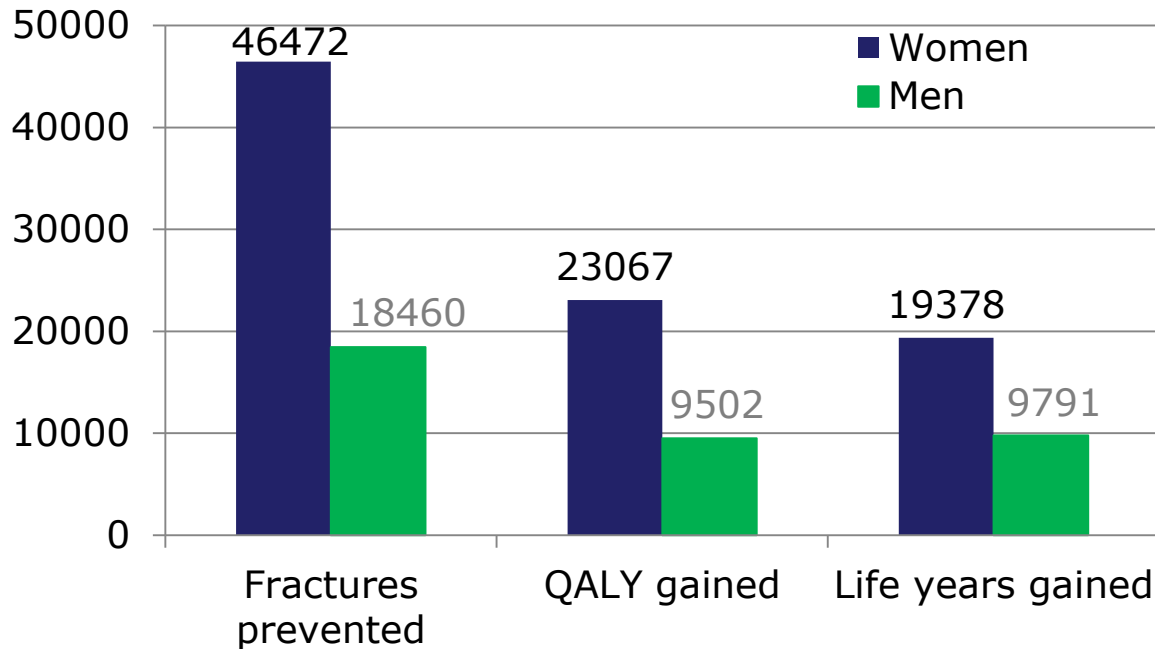

Hilgsmann et al. Osteoporos Int. 2017;28(3):833-840

## CAPHRI School for Public Health and Primary Care

Increasing life expectancy

⇒ increase in projected health impacts

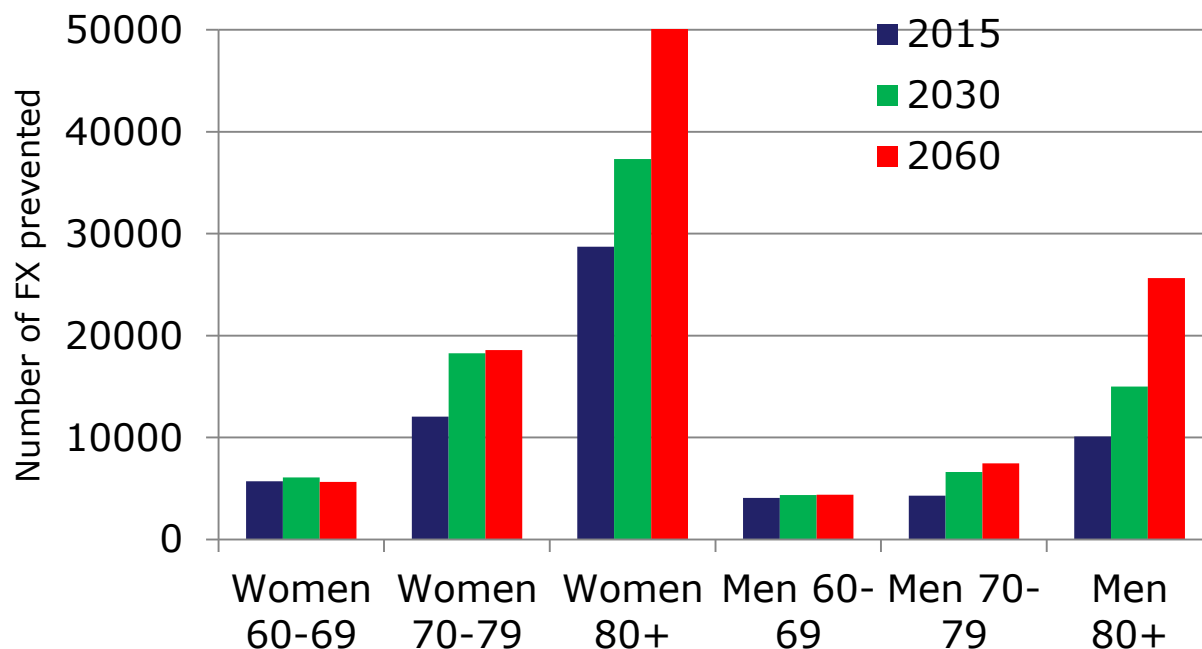

2030:  
+33%

2060:  
+77%

## CAPHRI School for Public Health and Primary Care



*Dairy products*

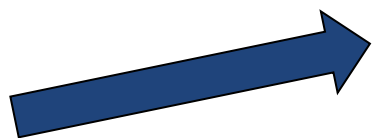

Public health impact

⇒ **Saving lives?**

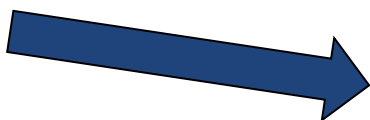

Economic impact

⇒ **Saving resources?**



# Measuring economic impact

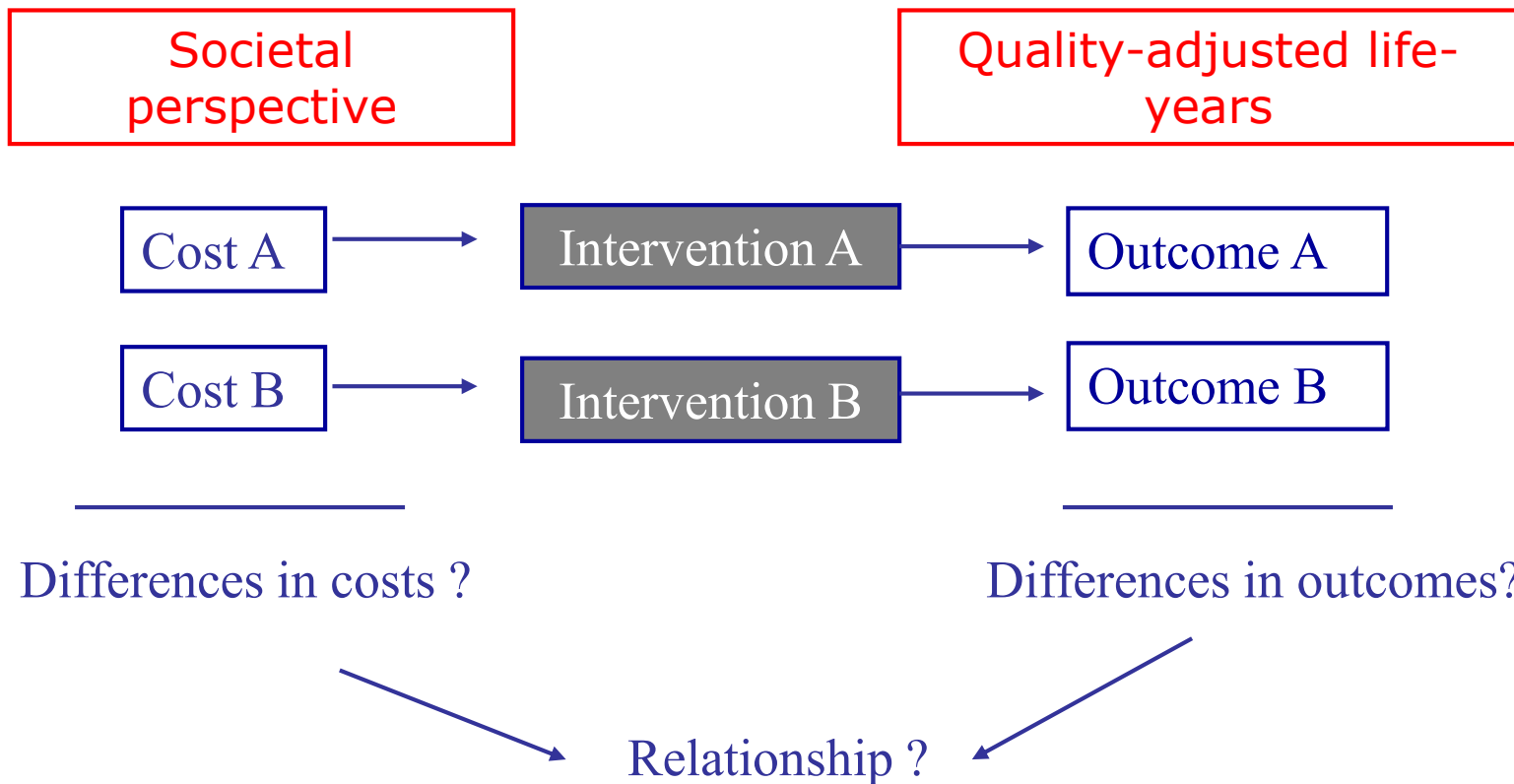

## CAPHRI School for Public Health and Primary Care



**COSTS**



↓ fracture costs

↑ dairy costs (€0.54/day for 2 products)



**OUTCOME**



More COSTS



More QALYs

## Measuring economic impact

Incremental cost-effectiveness ratio

$$\text{ICER} = (C_A - C_B) / (E_A - E_B) = \Delta C / \Delta E$$

*= The additional cost per extra unit of effect from the comparator treatment*

Intervention adopted if **ICER** <  $\lambda$  (= willingness to pay per effectiveness unit)

ICER < 2 X GDP (68,000€)



ICER < 30,000€



ICER > 2 X GDP  
(68,000€)



## CAPHRI School for Public Health and Primary Care

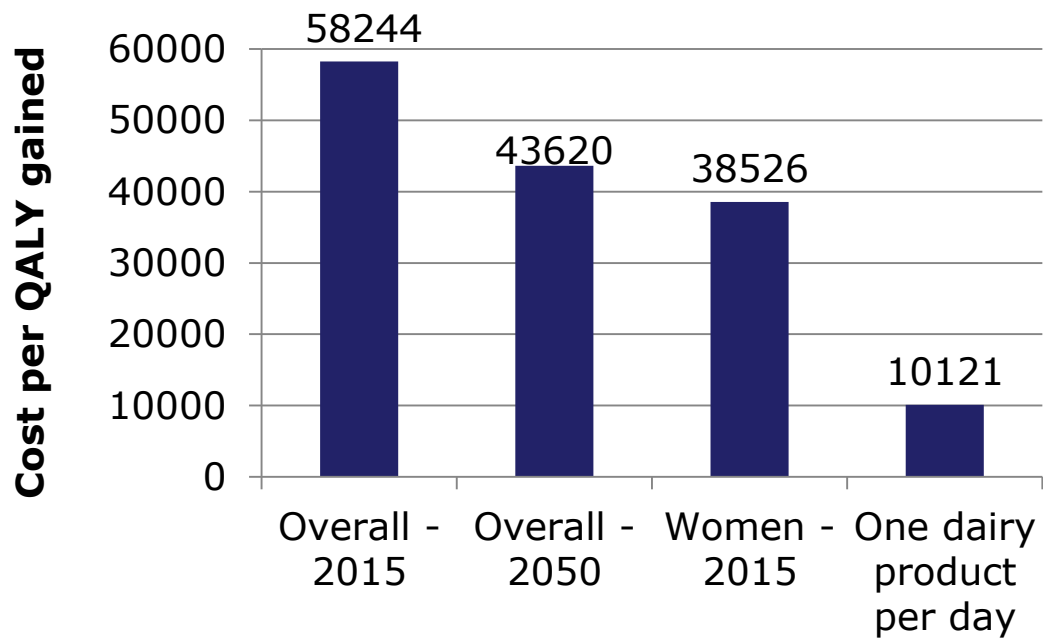

Hiligsmann et al. Osteoporos Int. 2017;28(3):833-840



## Cost-effectiveness dairy products

- General population aged over 60 years
  - ⇒ Border of efficiency
- Highly cost-effective (ICER <30,000)
  - ⇒ Women aged over 70 years
  - ⇒ Men aged over 80 years



Hilgsmann et al. Osteoporos Int. 2017;28(3):833-840

# High-risk population

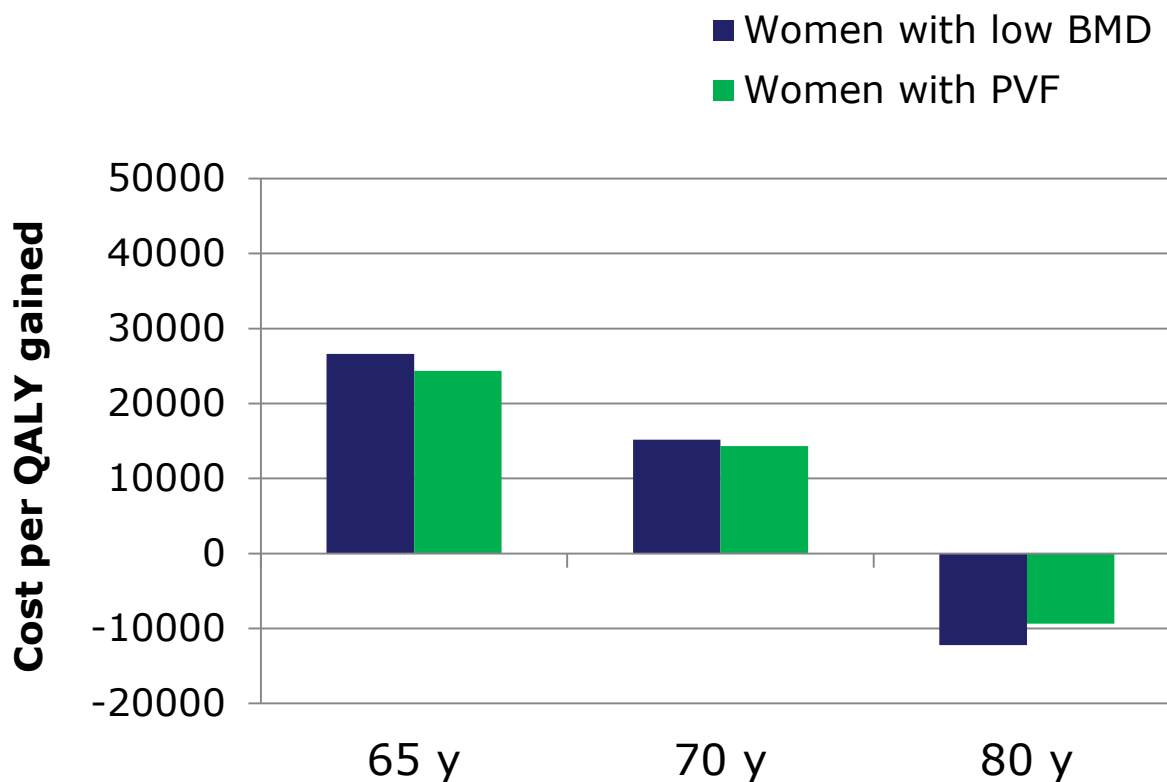

Ethgen et al. Osteoporos Int (2016) 27:301–308

## CAPHRI School for Public Health and Primary Care

Vitamin D and calcium food-fortification programme in the German female population aged 65 years and older



Annual net cost savings  
of €315 million

Annual total number of  
fractures prevented:  
36,705

Sandman et al. Public Health Nutr. 2015 Nov 16:1-10



*Dairy products*

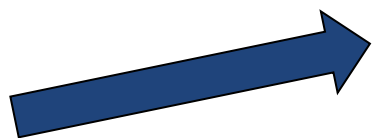

Public health impact

⇒ **Saving lives?**

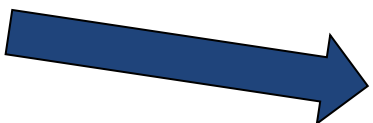

Economic impact

⇒ **Saving resources?**



⇒ **Value for money**



## Discussion

- Effectiveness of dairy products (real-life studies)
- Willingness to consume fortified dairy products
  - ⇒ large majority of Germans would be willing to consume vitamin D-fortified dairy products (1)
  - ⇒ higher willingness to consume for nutritional products
- Adherence to dairy products
- Increase in expected benefits in population aged over 80 years
- Other effects of calcium and vitamin D

(1) Sandman et al. Food Qual Prefer. 2015 Jul;43:53-62

## Dairy products



- Substantial public health impact → **saving lives**
  - Efficient allocation of resources → **saving resources**
- => Need for dairy products programmes/support





**Thank you for your  
attention**



Mickael Hiligsmann, PhD  
Assistant Professor in Health Economics & HTA  
Maastricht University  
[m.hiligsmann@maastrichtuniversity.nl](mailto:m.hiligsmann@maastrichtuniversity.nl)